



218 SERIES

HIGH-INTENSITY REMOTE DISPLAYS



Versatile enough for outdoor, indoor and washdown environments, Thurman Scale's 218 Series displays are easy to read in all lighting conditions and from distances up to 300 feet.



THURMANSCALE.COM

The NEMA 4X rated 218 Series 1.5" remote is ideal for washdown applications.



218 SERIES REMOTE DISPLAYS

Thurman Scale's 218 Series remote displays are made to perform in harsh, real-world weighing environments. From wet, dirty, dusty, hot or cold outdoor trucking conditions, to indoor washdown applications, you can expect reliable performance from the 218 Series displays. These displays also feature a unique learning ability that makes them compatible with every known scale instrument that has continuous output.

218 SERIES 5.0" FEATURES:

- 5.0" display characters.
- NEMA 3 rated enclosure for outdoor use.

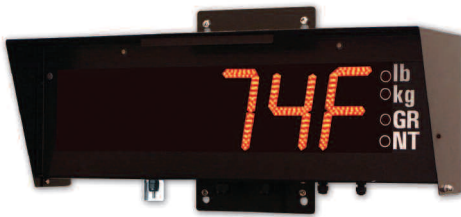

218 SERIES 1.5" FEATURES:

- 1.5" display characters.
- NEMA 4X rated enclosure for washdown.



SHARED FEATURES:

- Bright red, high-intensity LED.
- Auto-intensity sensor that automatically adjusts display brightness for existing lighting conditions.
- Gross and Net legends (GR-NT).
- LB and KG legends.
- Standard interfaces include RS232, RS485 and 20mA (active or passive). Wireless RS232 accessory sold separately.
- Programmable learning interface.
- Time and date capability (standard).
- Optional temperature module.

SPECIFICATIONS

Model	218 Series 5.0"	218 Series 1.5"
Display type	Six digit, high-intensity, red LED	Six digit, high-intensity, red LED
Digit height	5.0"	1.5"
Viewing distance	Up to 300 feet	Up to 75 feet
LED life expectancy	More than 11 years	More than 11 years
Time/date functions	Standard	Standard
Power	117 VAC ± 15%, 50/60 Hz, 100mA	117 VAC ± 15%, 50/60 Hz, 100mA
Storage temp.	0° F to 150° F (-18° C to 66° C)	0° F to 150° F (-18° C to 66° C)
Standard interfaces	RS232C, RS485 and 20mA	RS232C, RS485 and 20mA
Enclosure	NEMA 3 rated painted steel	NEMA 4X stainless steel
Mounting options	Pole or wall mount	Desk or wall mount bracket
Humidity	0% to 95% non-condensing	0% to 100% non-condensing
Shipping Weight	35 lbs	18 lbs
Accessories	Optional temperature module Wireless RS232 interface Pole and pole mounting bracket	Optional temperature module Wireless RS232 interface

218 SERIES 5.0" DIMENSIONS

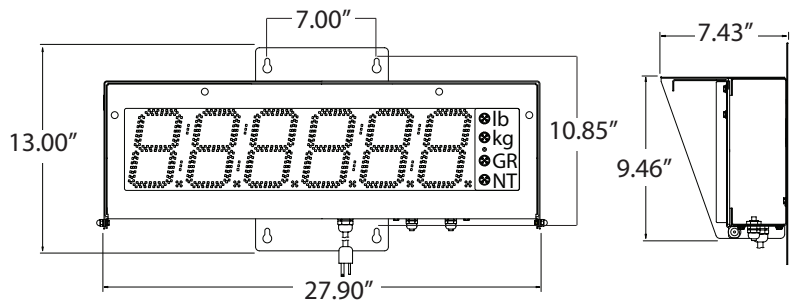

218 SERIES 1.5" DIMENSIONS

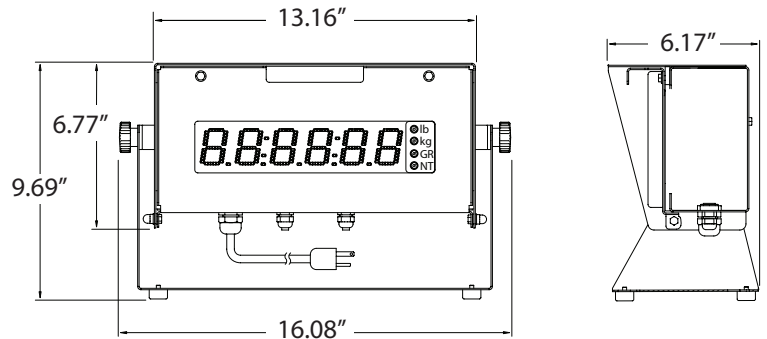

(800) 688-9741

Call between 8:00 a.m. – 5:00 p.m. CST
4025 Lakeview Crossing • Groveport, OH 43125 • (614) 221-9077
Internet Address: <http://www.thurmanscale.com>

